

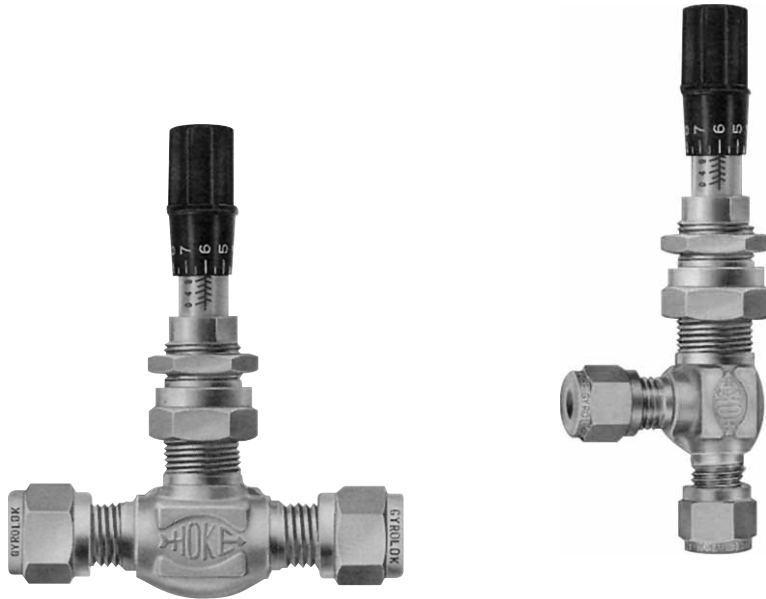

Milli-Mite® 1300 Series

Forged Metering Valves



Typical Applications

- Fine metering in medical and biochemical gas or vapor analysis
- Sampling and analyzing water and air pollution
- Chromatographs, mass spectrometers and other instruments where fine metering is required

Features & Benefits

- Metering accuracy - 18 turn displacement of stem provides unparalleled performance and repeatability
- 1° and 3° stems provide a wide flow range with ultra fine metering control
- Panel mounting is standard for all valves
- Precision orifice and close thread tolerances minimize hysteresis
- Micrometer vernier handle provides visual control and repeatable stem settings
- Dyna-Pak® wafer packing below the stem threads provides leak tight service
- Special High Tolerance NPT Thread

Technical Data

BODY*	316 stainless steel, brass
MAXIMUM OPERATING PRESSURE @ 70° F (21° C)	Brass <ul style="list-style-type: none">• 3000 psig (207 bar) 316 stainless steel <ul style="list-style-type: none">• 5000 psig (345 bar)
OPERATING TEMPERATURE RANGE	Brass <ul style="list-style-type: none">-65 to 400° F (-54° to 204° C) 316 stainless steel <ul style="list-style-type: none">-65° to 450° F (-54° to 232° C)
ORIFICE	.047" (1.19 mm)
CV FACTOR	1° stem = .010 Cv 3° stem = .024 Cv

* Consult factory for other materials

HOKE Incorporated

405 Centura Court • PO Box 4866 • Spartanburg, SC 29303

Phone (864) 574-7966 Fax (864) 587-5608

www.hoke.com • sales@hoke.com

metering valves

Milli-Mite® 1300 Series

Materials of Construction

	DESCRIPTION	MATERIAL
1	Handle, black anodized	Aluminum Alloy
2	Set Screw	Alloy Steel
3	Graduated sleeve	302 SS
4	Metering Stem	316 stainless
5	Panel nut	Brass
6	Upper spacer	316 stainless
7	Dyna-Pak® wafer	Teflon®
8	Lower spacer	316 stainless
9	Body	316 stainless or brass
10	Integrated seat & spacer	316 stainless
11	Orifice seal	Teflon®

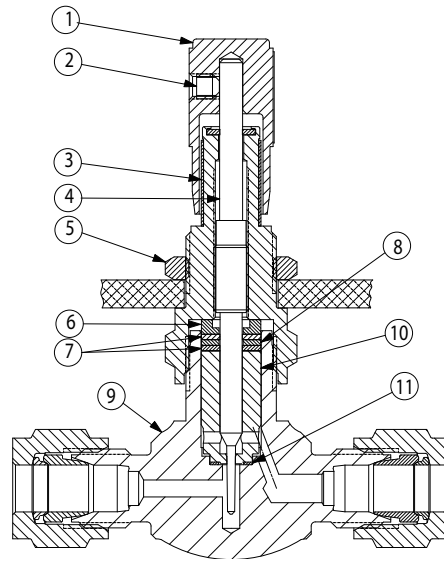

Dimensions

FLOW PATTERN	CONNECTIONS		DIMENSIONS		
	A INLET	B OUTLET	D	E	F
GLOBE	1/8" NPT Female	1/8" NPT Female	2.83" 72mm	1.75" 44mm	.50" 13mm
	1/8" NPT Male	1/8" NPT Male	3.25" 83mm	1.75" 44mm	
	1/8" NPT Male	1/8" Gyrolok®	3.25" 83mm	2.13" 54mm	
	1/4" NPT Male	1/4" NPT Male	3.25" 83mm	1.75" 44mm	
	1/8" Gyrolok®	1/8" Gyrolok®	3.25" 83mm	2.38" 60mm	
	1/4" Gyrolok®	1/4" Gyrolok®	3.25" 83mm	2.38" 60mm	
	3mm Gyrolok®	3mm Gyrolok®	3.25" 83mm	2.38" 60mm	
	6mm Gyrolok®	6mm Gyrolok®	3.25" 83mm	2.38" 60mm	
ANGLE	1/8" NPT Female	1/8" NPT Female	3.75" 95mm	1.28" 33mm	
	1/8" NPT Male	1/8" Gyrolok®	3.75" 95mm	1.28" 33mm	
	1/8" Gyrolok®	1/8" Gyrolok®	4.00" 102mm	1.63" 41mm	
	1/4" Gyrolok®	1/4" Gyrolok®	4.00" 102mm	1.63" 41mm	
	3mm Gyrolok®	3mm Gyrolok®	3.25" 83mm	1.38" 41mm	
	6mm Gyrolok®	6mm Gyrolok®	3.25" 83mm	1.38" 41mm	

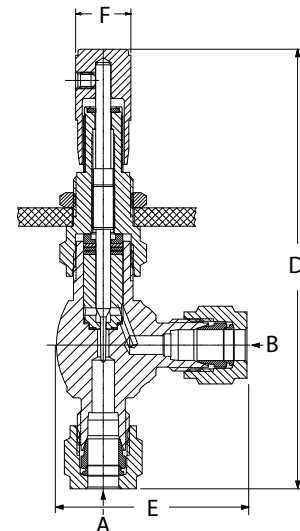
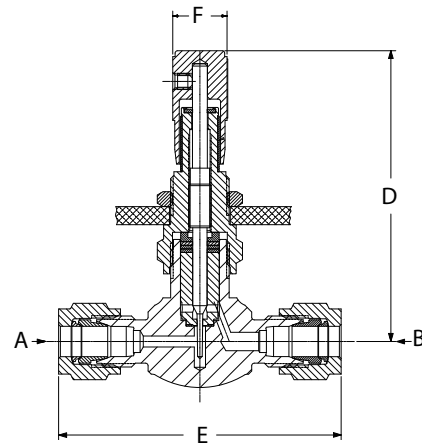

Dimensions for reference only, subject to change.

Panel mounting

Panel hole = .52" (13 mm) diameter

Panel thickness = .16" (4 mm) maximum

Milli-Mite® 1300 Series

Reference Flow Curves

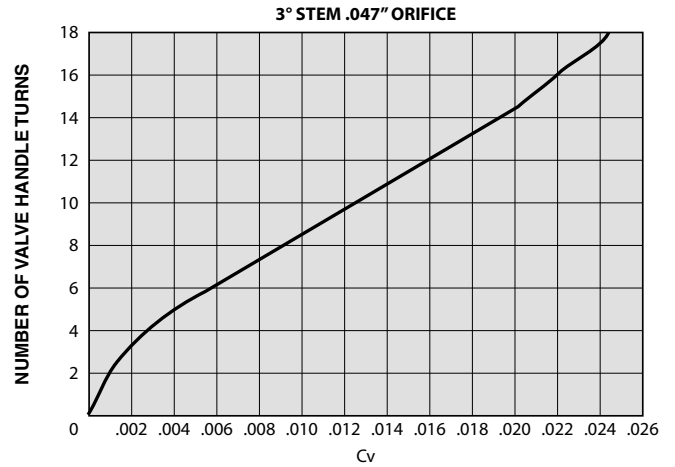
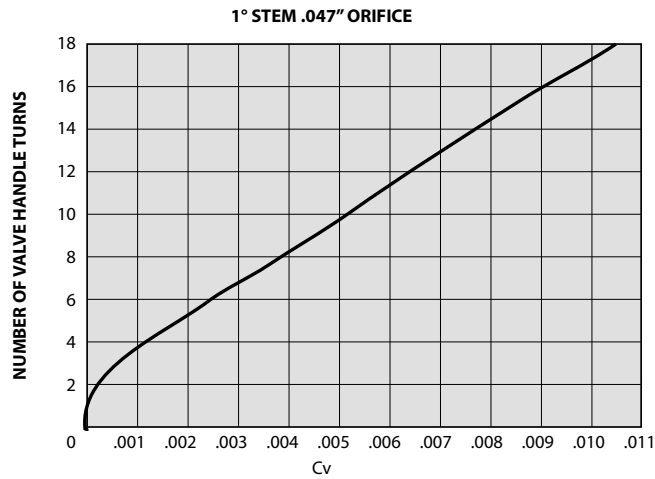

How to Order

FLOW PATTERN	CONNECTIONS		ORDER BY NUMBER			
	A INLET	B OUTLET	316SS VALVES		BRASS VALVES	
			1° STEM	3° STEM	1° STEM	3° STEM
			CV = 0.010	CV = 0.024	CV = 0.010	CV = 0.024
GLOBE	1/8" NPT Female	1/8" NPT Female	—	1315F2Y	—	—
	1/8" NPT Male	1/8" Gyrolok®	—	—	1335H2B	1315H2B
	1/8" NPT Male	1/8" NPT Male	—	—	1335M2B	1315M2B
	1/4" NPT Male	1/4" NPT Male	1335 M4Y	1315M4Y	1335M4B	1315M4B
	1/8" Gyrolok®	1/8" Gyrolok®	1335G2Y	1315G2Y	1335G2B	1315G2B
	1/4" Gyrolok®	1/4" Gyrolok®	1335G4Y	1315G4Y	1335G4B	1315G4B
	3mm Gyrolok®	3mm Gyrolok®	1335G3YMM	1315G3YMM	—	—
6mm Gyrolok®	6mm Gyrolok®	1335G6YMM	1315G6YMM	—	—	
ANGLE	1/8" NPT Female	1/8" NPT Female	—	—	1345F2B	1325F2B
	1/8" NPT Male	1/8" Gyrolok®	1345H2Y	1325H2Y	1345H2B	1325H2B
	1/8" Gyrolok®	1/8" Gyrolok®	1345G2Y	1325G2Y	1345G2B	1325G2B
	1/4" Gyrolok®	1/4" Gyrolok®	1345G4Y	1325G4Y	1345G4B	1325G4B
	3mm Gyrolok®	3mm Gyrolok®	1345G3YMM	1325G3YMM	—	—
	6mm Gyrolok®	6mm Gyrolok®	1345G6YMM	1325G6YMM	1345G6BMM	1325G6BMM
	1/8" NPT Female	1/8" NPT Female	—	—	1345F2B	—

FOR YOUR SAFETY

IT IS SOLELY THE RESPONSIBILITY OF THE SYSTEM DESIGNER AND USER TO SELECT PRODUCTS SUITABLE FOR THEIR SPECIFIC APPLICATION REQUIREMENTS AND TO ENSURE PROPER INSTALLATION, OPERATION AND MAINTENANCE OF THESE PRODUCTS. MATERIAL COMPATIBILITY, PRODUCT RATINGS AND APPLICATION DETAILS SHOULD BE CONSIDERED IN THE SELECTION. IMPROPER SELECTION OR USE OF PRODUCTS DESCRIBED HEREIN CAN CAUSE PERSONAL INJURY OR PROPERTY DAMAGE.

Ordering Options

Spare Parts

Spare parts and repair kits are available for all needle valves. Please contact your distributor for specific information.

Cleaning and Testing

When ordering, please specify if oxygen cleaning or helium leak testing is required.

Additional Sizes

Additional sizes and options are available on special request. Please consult your local HOKE distributor.