

5600 SERIES

450 to 4,500 PSIG



PILOT OPERATED RELIEF VALVES

Features

- High Flow Capacity
- Ultra Fast Response
- Stable Cracking Pressure

Applications

- Aircraft Hydraulic Systems
- Ordnance Vehicle Systems
- Rapid Firing Cannons & Grenade Launchers
- Hydraulic Power Units
- Replacement of Hydraulic Accumulators
- Military Ground Support Systems
- High Pressure Manifold Systems

Technical Data

Materials of Construction

Body – 2024-T4/T351 Aluminum or 303 Stainless Steel

Seals – Buna N, EPR and Viton®

Internal metal components are 400 Series corrosion resistant stainless steel.

Pressure Ratings

Operating Pressure –
450 to 4,500 PSIG (31 to 310 BAR);
Specify Cracking Pressure

Internal Leakage –
Inline -4 and -6 are 15 cc/min. 2Q Inline
-8 and up and all right angle models are
30 cc per minute max.

How It Works

CLOSED

Upstream fluid is isolated from return by the pilot valve and the main piston. Fluid passes behind the main piston through the self-cleaning orifice. Leakage is extremely low because the main piston is slightly pressure unbalanced against the floating seat.

CRACKING

Pilot valve senses system pressure at the main valve inlet. The instant pressure reaches cracking pressure of the pilot valve it permits flow through it to return. Pressure behind the main piston is relieved causing the main piston to open. Force on the pilot valve is maintained by upstream pressure, preventing chatter.

FLOWING

As upstream pressure increases above the crack setting, the pressure drop across the orifice also increases, forcing the main piston against the bias spring, modulating the valve opening as a function of the slight increases in upstream pressure.

RESEAT

When the upstream pressure drops below setting, pilot valve reseats and stops flow through pilot valve. Pressure drop across the self-cleaning orifice drops to zero. The bias spring returns the main piston against the floating seat. Unbalanced force, caused by area difference between the main piston O-ring seal and the sharp edged nose of the main piston, pressure loads the main piston firmly on the seat.

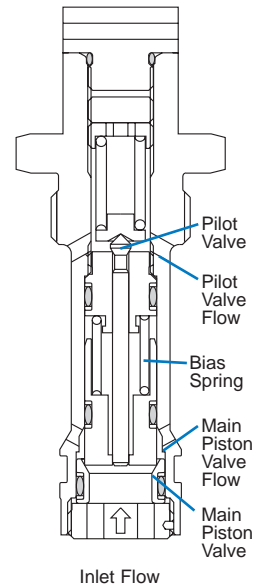

CIRCLE SEAL CONTROLS, INC.

A CIRCOR International company

Certified to ISO 9001

2301 WARDLOW CIRCLE • CORONA, CALIFORNIA • 92880 • TEL: (951) 270-6200 • FAX: (951) 270-6201

5600 SERIES

450 to 4,500 PSIG

How To Order

VARIATION

- None - Inline
- C - Cartridge
- R - Right Angle
- MC - Manual Cartridge

BASIC MODEL NUMBER

5600 Series

O-RING MATERIAL & TEMPERATURE

- 77 - Buna N -65° F to +275° F
- 62 - Ethylene Propylene -65° F to +255° F
- 32 - Viton® -40° F to +275° F

Notes:

Series shown not for use with Skydrol. Consult factory for model numbers of relief valves for Skydrol applications.

Cracking Pressure is $\pm 2\%$ at 30 cc/min. flow.

Viton® is a registered trademark of DuPont Dow Elastomers.

Please consult your Circle Seal Controls Representative or our factory for information on special connections, operating pressures and temperature ranges.

C 56 77 A - 12 BB - 450

CRACKING PRESSURE

Specify cracking pressure setting in PSIG. Range is 450 to 4300 PSIG.

450 - 450 PSIG

CONNECTIONS

- BB - Inline, MS33649
- Q - Cartridge Type
- RR - Right Angle, MS16142 (SAE)
- SS - Right Angle, Flange Fitting, MS3914

VALVE SIZE

Tube Sizes in 1/16" Increments, except Cartridge Valve (Q).

12 - 3/4"

BODY MATERIAL

- A - 2024-T4/T351 Aluminum
- T - 303 Stainless Steel

Dimensions

INLINE 5600 SERIES

Dash No.	Size	Tube O.D.		A	B	C	D
		Nom.					
4BB	1/4"	0.250		4.000	0.688	0.438	1.000
6BB	3/8"	0.375		5.000	0.813	0.500	1.000
8BB	1/2"	0.500		6.000	1.000	0.625	1.375
12BB	3/4"	0.750		7.000	1.375	1.705	1.375
16BB	1"	1.000		7.000	1.750	1.705	1.375
24BB	1-1/2"	1.500		7.000	2.250	1.705	1.500

The Inline Piloted Relief Valve envelope conforms to MS28893.

Dimensions in inches.

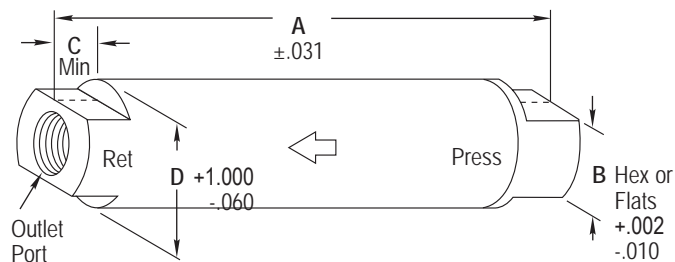

CARTRIDGE TYPE C5600 SERIES

Both a low and high flow cartridge valve have been developed for use in modular hydraulic systems. These standard units utilize the same internal parts as our inline valve. Order the 2Q size for flows up to 110 gallons per minute. Both the Aluminum and Stainless Steel housings contain Stainless Steel internal parts. Cracking pressures to 4300 psi.

Weight - Model No. 2Q

- Aluminum .29 lbs.
- Stainless Steel .65 lbs.

C5600 2Q

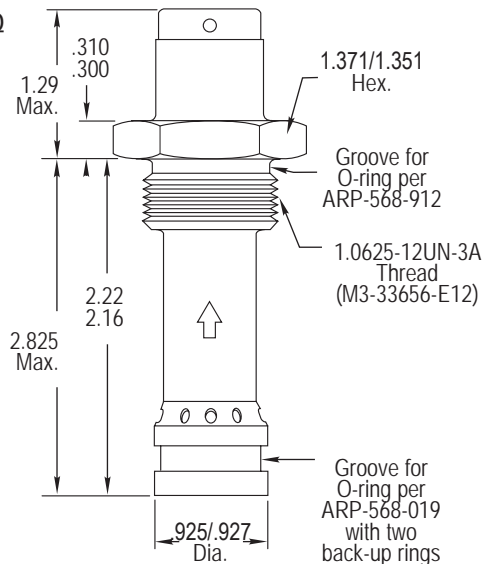

Manual Cartridge MC5600 Dimensions

The MC5600 is a user adjustable version of the basic product. It allows rapid prototyping of a hydraulic system for optimum performance. The "K" option provides a Hand Knob. The "F" option provides a Tamperproof Cover once the discrete setting has been applied to the system. The MC5600 is also available in the right angle configuration shown below.

ORDERING INFORMATION

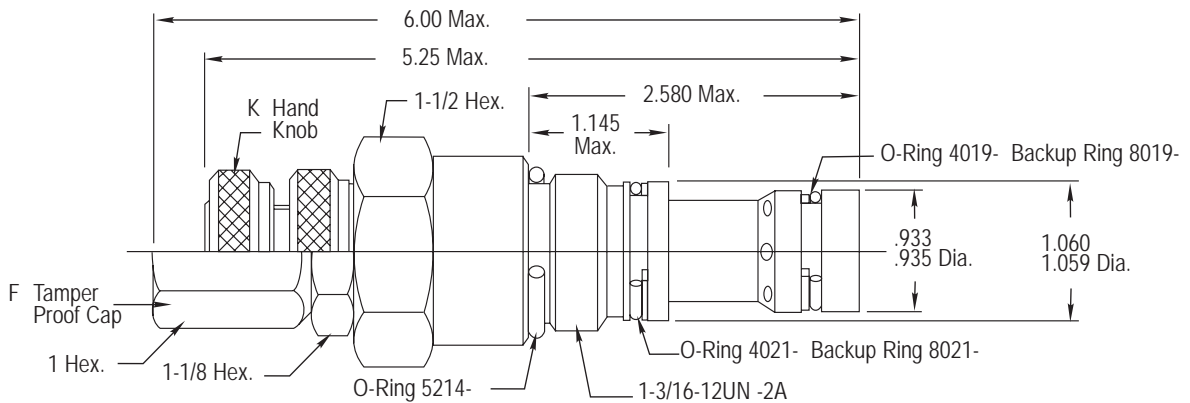
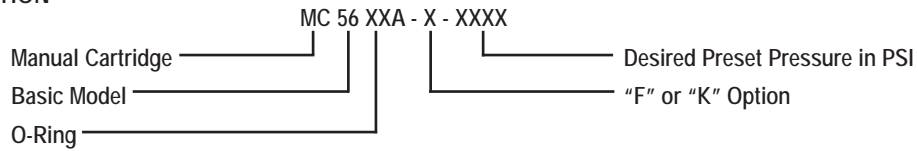

RIGHT ANGLE R5600 SERIES

Qualified to MIL-V-52687, standard C5600 Series Cartridge Valves can be mounted in right angle ported bodies. Straight tube threads are available in sizes 8 through 12 per MS16142, and in sizes 16 through 24 with flanges per MS39314 (military equivalents of SAE). When ordering QPL valves to requirements of MIL-V-52687, specify MIL-V-52687 in brackets underneath the part number. For dimensional information on R5600 mounting bodies, consult factory.

Right Angle R5600 SS with Mounting Body

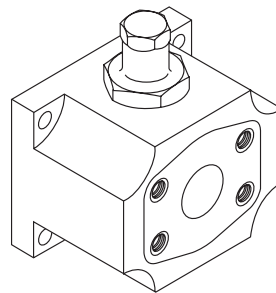

Right Angle R5600 RR with Mounting Body

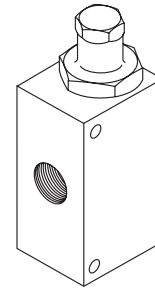

Flow Data

MAXIMUM FLOWS TO MIL-V-52687

Cracking Pressure Setting 90°F	Maximum Rise To Rated Flow (PSI)	Maximum Decrease To Reset (PSI)	Maximum Decrease Of Setting @ 275°F	Rated Flow @ 90± 20°F (GPM)								
				4	6	8	10	12	16	20	24	2Q
450 - 774	40	25	35	3	4	12	20	32	48	60	60	60
775 - 1349	60	55	45	3	5	12	20	32	48	70	80	80
1350 - 2199	80	90	90	3	6	12	20	32	48	80	100	100
2200 - 4300	100	180	180	3	7	12	20	32	48	86	110	110

Special Project Valves for Unique Applications

Circle Seal Controls' engineers can analyze your special requirements when a standard valve cannot be fitted into your application. Examples are shown below of valves which are basically similar to the C5600 series but which require special bodies or other unique features.

P2-776 & P10-776 (Manned Aircraft)

The P2-776 was designed to replace a direct operating relief valve on an existing front line fighter aircraft handling 32 gallons per minute of MIL-H-5606 at 3750 PSI. A unit in a similar envelope, the P10-776 has successfully passed tests for a fighter program to flow 104 gallon per minute in the same size package.

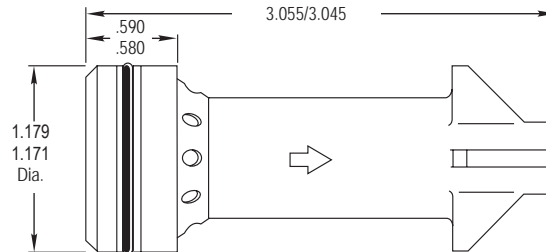

P12-776 (Manned Aircraft)

The P12-776 was designed specifically for fast response at high flow so that accumulators could be eliminated on a manned aircraft program. It achieves 32 gallons per minute flow in 5 mil sec. with a pressure drop of 3850 PSI.

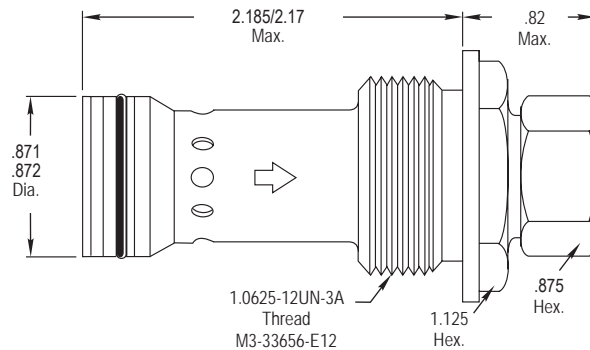

P16-776 (Special Mining Equipment)

The P16-776 was designed to flow 100 gallons per minute of water in hydraulic mining equipment. The valve itself is mounted on the end of a high pressure hose string. It vents overboard. The pressure rise over cracking pressure is only 120 PSI.

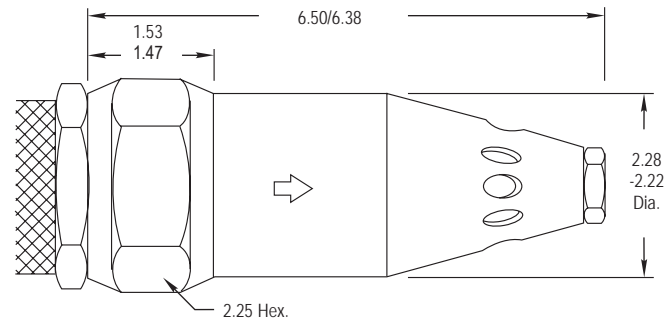

P15-776 (Rapid Firing Gun)

The P15-776 was developed for use on a hydraulically driven rapid firing cannon. It must be able to perform during 3 milliseconds actuating cycles.

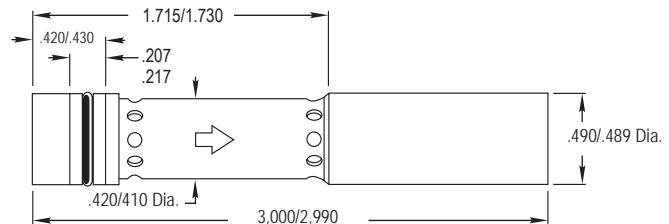

Certified to ISO 9001

2301 WARDLOW CIRCLE • CORONA, CALIFORNIA • 92880 • TEL: (951) 270-6200 • FAX: (951) 270-6201