



# 4200 Series

316 Stainless Steel Bellows Sealed Valves  
(0.156"/3.962 mm orifice)

## Introduction

With its wide operating temperature range of -320° to 1200° F (-196° to +649° C), the 4200 Series meets the demands of many critical fluid control conditions. Operating pressure range is 0-2000 psig. Applications include high temperature liquid metals, cryogenic service, and gas analysis.



## Typical Applications

- Critical gas analysis
- High temperature liquid metals
- Cryogenics
- Reactive and toxic fluids
- Sealing cesium or isotope containers
- High vacuum systems

## Technical Data

<b>MAXIMUM OPERATING PRESSURE</b>	Hard seats: 2000 psi @ 600° F (141 kg/cm <sup>2</sup> @ 316° C) Soft seats: 500 psi @ 350° F (35 kg/cm <sup>2</sup> @ 175° C)
<b>HIGH VACUUM</b>	to 10 <sup>-5</sup> Torr
<b>TEMPERATURE RANGE</b>	-320° F to +1200° F (-195° C to +632° C)
<b>ORIFICE SIZE</b>	0.156 (3.962 mm)
<b>Cv FACTOR</b>	0.36 (maximum)
<b>INTERNAL VOLUME</b>	0.18 cubic inches

## Features & Benefits

- Positive plug return on all valves prevents plug sticking in severe service
- No torque transmitted to bellows – Hex guide mates with hex broach in bonnet
- Secondary o-ring seal in upper bonnet prevents leakage if bellows is damaged
- Non-rising stem prevents galling or seizing of stem threads
- Heavy-duty welded bellows provides long cycle life and assures leak tight service. Long size bellows insures full lift and utilization of full orifice area.
- All-welded design for high-temperature and high-pressure service
- Plugs and bellows are replaceable on all gasketed types
- Valves can be base or panel mounted – add prefix “D” to part number for panel mounted
- Variety of materials and modifications
- Special High Tolerance NPT Thread

packless valves

## HOKE Incorporated

405 Centura Court • PO Box 4866 (29305) • Spartanburg, SC 29303  
Phone (864) 574-7966 Fax (864) 587-5608  
www.hoke.com • sales@hoke.com

# 4200 Series

## Materials of Construction

DESCRIPTION	4251F2Y 4251F4Y 4251N6Y 4251G4Y	4212F4Y	4235Q6Y	4213Q6Y
	1 Body, bar stock	316 stainless steel	316 stainless steel	316 stainless steel
2 Bellows assembly	316 stainless steel	316 stainless steel	316 stainless steel	316 stainless steel
3 Seal, bellows-to-body	Teflon®	316 stainless steel	316 stainless steel seal welded	316 stainless steel seal welded
4 Disc or plug	Teflon®	316 stainless steel	316 stainless steel stellited	316 stainless steel
5 Packing, secondary	O-ring seal	O-ring seal	Garlock® 908	O-ring seal
6 Bonnet	aluminum	303 stainless steel	303 stainless steel	303 stainless steel
7 Handle	Nylon wheel	aluminum cross, die cast	303 stainless steel	aluminum cross, die cast

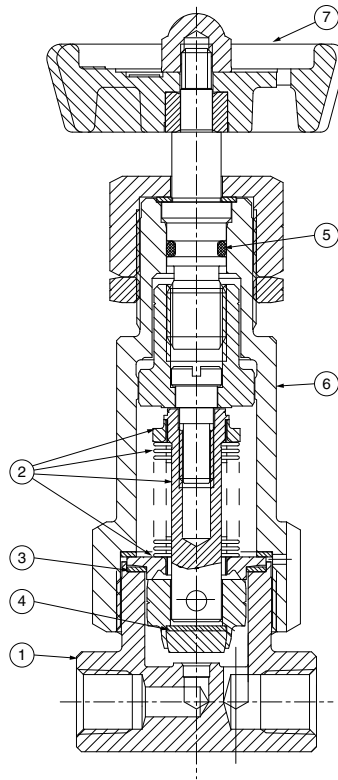

## Dimensions

CONNECTIONS	D (OPEN)	E	F	H	H'	PANEL MOUNTING		BASE MOUNTING
						HOLE SIZE	MAX. THICKNESS	
4212F4Y	inch	4 7/16	1 1/2	2 3/8	1 3/32	2 3/8	2 3/32	3/16
	mm	113	38	60	10	60	20	5
4251F4Y	inch	4 7/16	1 1/2	1 13/16	1 13/32	2 9/32	2 5/32	3/16
	mm	113	38	46	10	58	20	5
4251G4Y	inch	4 5/8	2 5/32	1 13/16	1 15/32	2 1/32	2 5/32	3/16
	mm	117	55	46	12	64	20	5
4213Q6Y	inch	4 3/8	7 1/2	2 3/8	5/16	2 9/32	2 5/32	3/16
	mm	111	191	60	8	58	20	5
4235Q6Y	inch	6 1/2	7 1/2	2 3/8	5/16	2 9/32	2 5/32	3/16
	mm	165	191	67	8	58	20	5
4212G4Y	inch	4 5/8	2 5/32	1 13/16	1 15/32	2 7/32	2 5/32	3/16
	mm	117	55	46	12	64	20	5

2 mounting holes 10-32 NF Thd., 0.187 min. full thd.

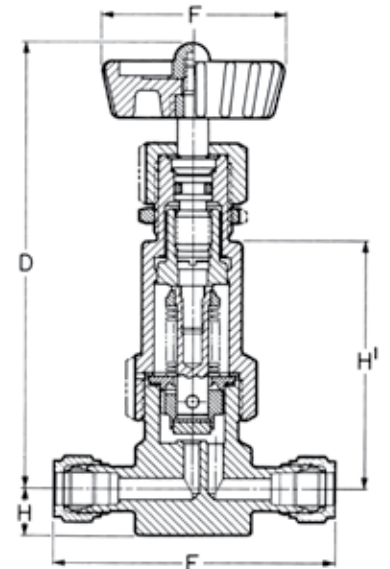

Dimensions for reference only, subject to change.

# 4200 Series

## How to Order

Order valve by part number shown in chart.

	CONNECTIONS INLET & OUTLET	ORDER BY PART NUMBER	CV FACTOR	OPERATING PRESSURE	TEMPERATURE RANGE
PIPE ENDED MODELS	¼" NPT Female	4212F4Y	0.33	2000 @ 600° F	-320° F to 600° F (-196° C to 316° C)
		4251F4Y	0.36	500 @ 350° F	-65° F to 350° F (18° C to 177° C)
GYROLOK®	¼" Gyrolok® tube fitting	4212G4Y	0.33	2000 @ 600° F	-320° F to 600° F (-196° C to 316° C)
		4251G4Y	0.36	500 @ 350° F	-65° F to 350° F (18° C to 177° C)
SOCKET WELD MODELS	⅜" O.D. socket weld	4212N6Y	0.33	2000 @ 600° F	-320° F to 600° F (-196° C to 316° C)
		4251N6Y	0.36	500 @ 350° F	-65° F to 350° F (18° C to 177° C)
3" TUBE EXTENSIONS SOCKET WELD TO BODY	Socket weld to body	4213Q6Y	0.33	2000 @ 600° F 400 @ 900° F	-320° F to 900° F (196° C to 482° C)
		4235Q6Y	0.33	2000 @ 600° F 250 @ 1200° F	-320° F to 1200° F (196° C to 649° C)

### FOR YOUR SAFETY

IT IS SOLELY THE RESPONSIBILITY OF THE SYSTEM DESIGNER AND USER TO SELECT PRODUCTS SUITABLE FOR THEIR SPECIFIC APPLICATION REQUIREMENTS AND TO ENSURE PROPER INSTALLATION, OPERATION AND MAINTENANCE OF THESE PRODUCTS. MATERIAL COMPATIBILITY, PRODUCT RATINGS AND APPLICATION DETAILS SHOULD BE CONSIDERED IN THE SELECTION. IMPROPER SELECTION OR USE OF PRODUCTS DESCRIBED HEREIN CAN CAUSE PERSONAL INJURY OR PROPERTY DAMAGE.



Pipe ended  
4212F4Y



3" Tube extensions  
4235Q6Y



Socket weld  
4251N6Y